

P E T K I T

PURAX

INSTRUCTION MANUAL

English ----- 1 - 24

Deutsch ----- 25 - 48

En français ----- 49 - 72

Português ----- 73 - 96

Español ----- 97 - 120

日本語 ----- 121 - 144

繁体 ----- 145 - 168

한국어 ----- 169 - 192

Italiano ----- 193 - 216

Русский ----- 217 - 240

Please read the User Manual carefully before using the product and keep it properly.

A MESSAGE TO OUR VALUED CUSTOMERS

- Thank you for choosing PETKIT PURA X Self-cleaning cat litter box. We at PETKIT have done our best to make life easier for you and your pet through the miracle of technology.
- Before using this product, please carefully read the user's manual. By setting up and using this product, you acknowledge that you have already read and accepted the safety measures listed below.
- We are not liable and will not accept responsibility for any accidents or injuries that result from improper use of this product.
- Concerning this notice, we reserve the rights of interpretation and revision.

USER SAFETY GUIDE

*** Failure to follow the safety measures outlined below can result in product malfunction or other unforeseen mishaps.**

- Please install and use product exactly as instructed in the User's Manual.
- Pets under the age of 6 months should not use this product.
- For indoor use only. Do not expose product directly to sunlight for extended periods of time. Do not place near an open flame.
- Even though this product uses low current, pets can still damage the power cord if they chew on it, preventing the product from getting power. Please ensure pets use product as intended.
- Only use the provided power adapter. Using a different power adaptor may result in damage to the product or potential safety hazards.
- Make sure the product remains parallel to the ground, otherwise the concentrated purifying liquid may pour out and cause product malfunction.
- Do not allow the bottom half of the product to be dipped or submerged in water.
- Repairs should be done under the guidance of a professional to avoid safety hazards.
- When leaving for a long period of time, make sure there is enough space in the waste collection bin.
- If you encounter any problems while using this product, please contact us immediately.

FUNCTIONS

1. xSecure – 6 Levels of Safety

- ① Thermal sensor : The product will be suspended if the cat enters.
- ② Infrared Sensor: The entrance is equipped with an infrared sensor that will halt product operation if it detects a cat nearby.
- ③ Weight sensor: the interior of the litter box is equipped with 4 weight sensors. If a cat enters the litter box, these sensors will detect the cat and cease the operation.
- ④ Anti-Pinch Infrared Sensors: There are two pairs of infrared sensors installed on the bottom inside the litter box. While the product is operating, if a cat approaches, the device will immediately cease the operation.
- ⑤ Smart Detection, Remote Alerts: Use the APP to get smart updates and early alerts of abnormal activity.
- ⑥ Accident Protection System: Sensors system will be activated before operating. The product will shutdown and send an alert if any of the sensors malfunction.

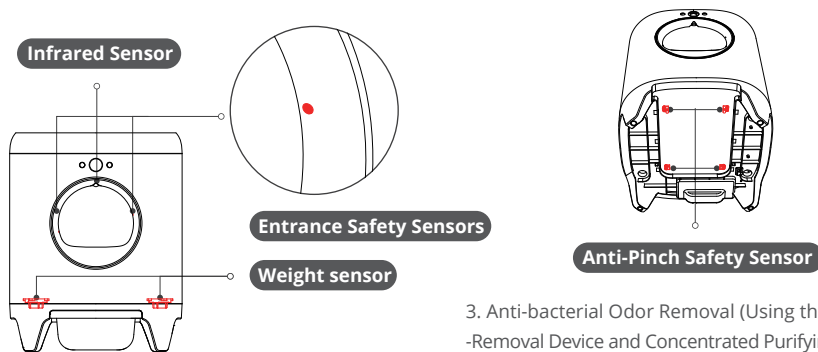

2. Use multiple types of cat litter.

The cat litter filter net is effective at filtering both plant litters and bentonite litters, and mixture litters as well.



3. Anti-bacterial Odor Removal (Using the Odor-Removal Device and Concentrated Purifying Liquid)

Through experimental verification, this product has proven to be effective at removing unpleasant odors and formaldehyde, while also killing common forms of harmful bacteria. (colon bacillus, staphylococcus aureus, pseudomonas aeruginosa, candida albicans, salmonella typhimurium, klebsiella pneumoniae, etc.)

Odor-removal device

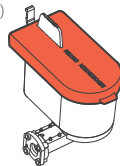

PACKING LIST

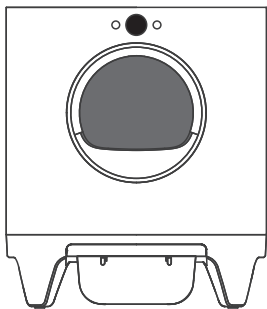

Litter Box *1

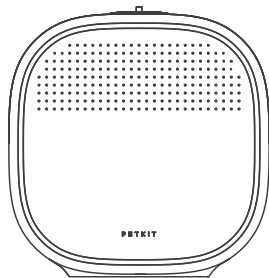

Litter Box Cover *1



Trash Bag *1
(in the accessories box)



Litter Pad *1

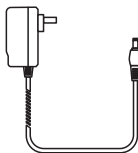

Power Adapter *1
(in the accessories box)



Concentrated
Purifying Liquid *4
(in the accessories box)

PRODUCT DESCRIPTION

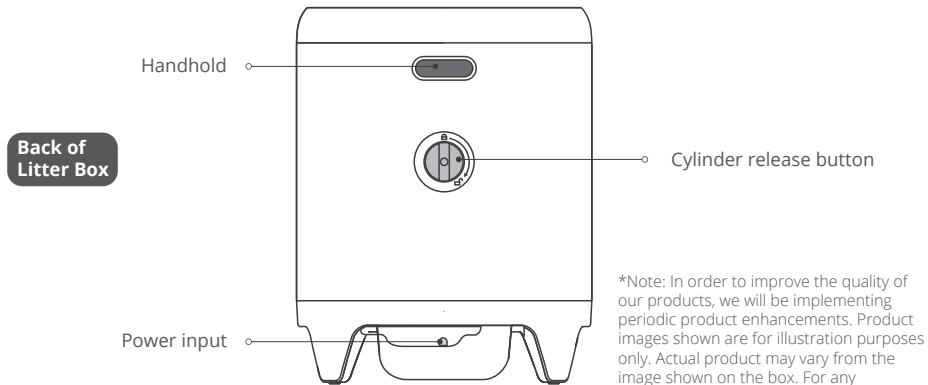
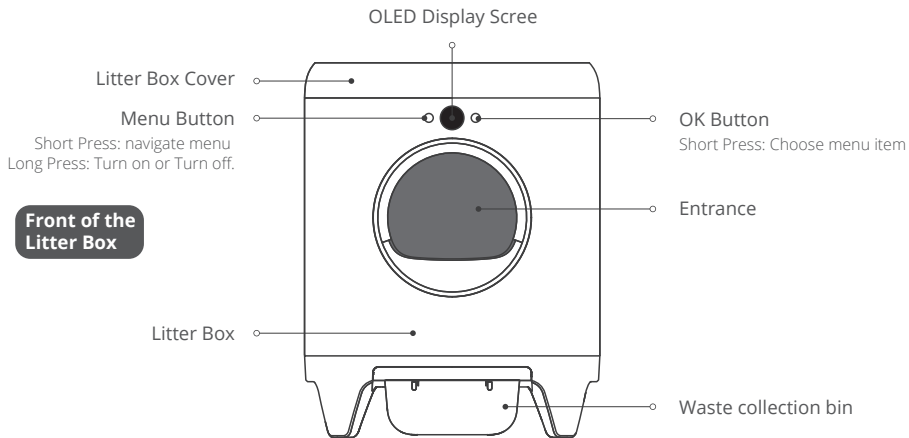

PRODUCT DESCRIPTION

Top View of Litter Box

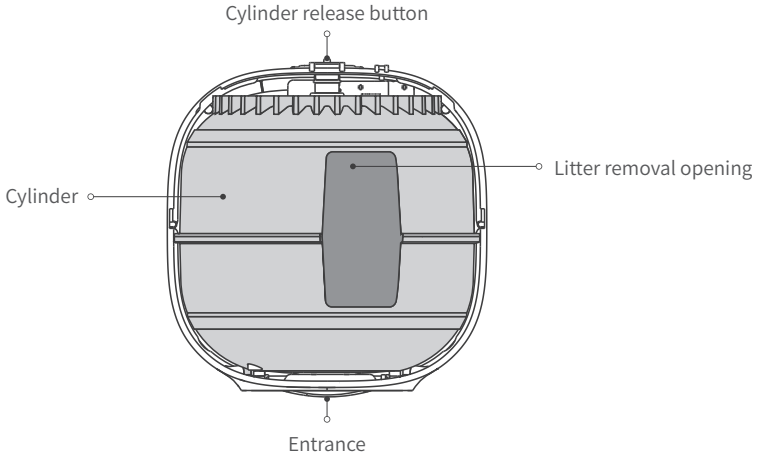

Top View of Litter Box (After removing the cylinder)

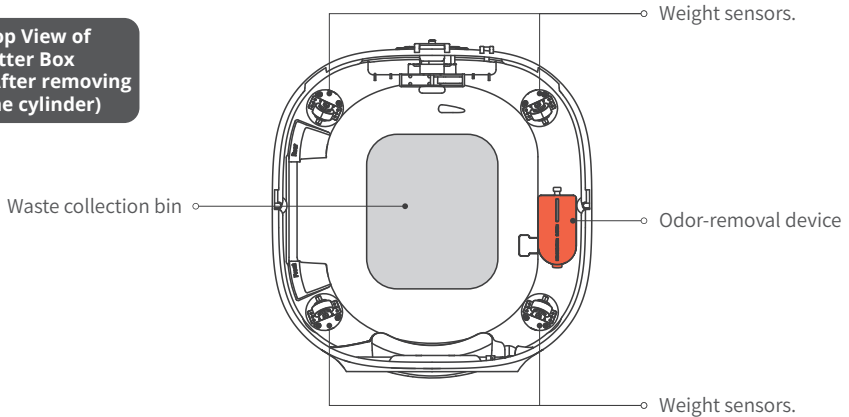

| SCAN THE QR CODE AND WATCH THE SET UP VIDEO



Scan QR Code to Watch a Video on How
to Set Up and Use Your Litter Box

TAKE OUT CYLINDER

1. To unlock the cylinder that holds the concentrated solution, twist the release button for the cylinder in a clockwise direction. The release button is located on the end of the cylinder on the back of the litter box. *If the covering has not already been removed from the litter box, make sure to remove it by sliding it off before taking out the cylinder.

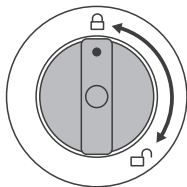

Cylinder Locker

2. Use both hands to lift upward as picture instructed.

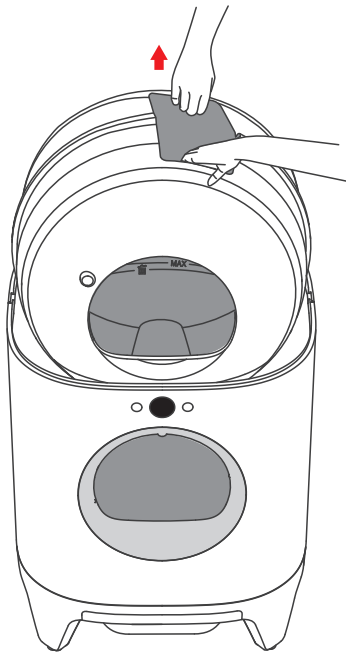

ADD THE PURIFYING LIQUID

* To ensure the effectiveness of odor removal, please only use the "PETKIT Concentrated Purifying Liquid for the PETKIT Smart Automatic cat Litter Box".

1. Remove the orange silicone lid of the odor-removal device and pour the entire bottle of concentrated Purifying Liquid into the odor-removal device.

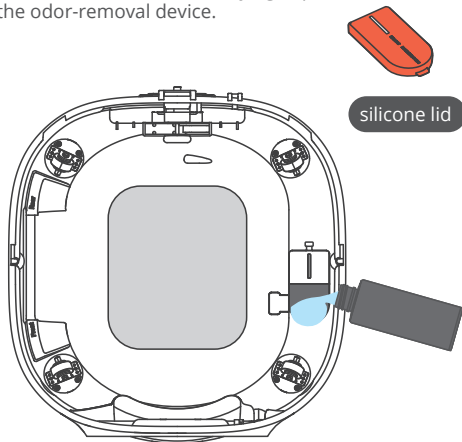

2. Reattach the silicone lid to the odor-removal device, make sure it is securely fastened.

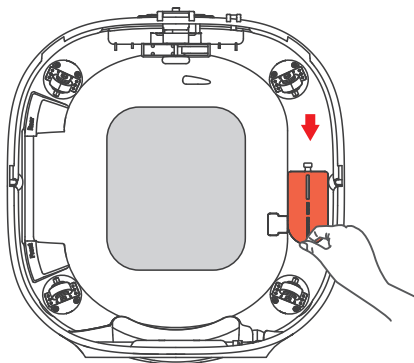

INSTALL THE CYLINDER AND POUR IN THE LITTER

1. Use both hands to lift upward, reinstall the cylinder into the back of the litter box.

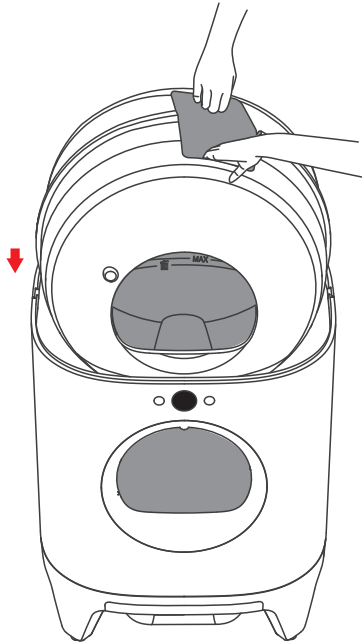

INSTALL THE CYLINDER AND POUR IN THE LITTER

2. Pour the cat litter into the opening in the cylinder. The amount of cat litter should not exceed the MAX Line indicated inside the cylinder.)



MAX Line
The amount of cat litter should not exceed the MAX line.

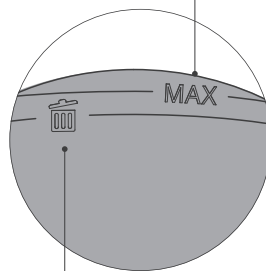

The "Empty Litter Line"

* The "Empty Litter Line" is determined by the capacity of the waste collection bin.

When the amount of kitty litter remaining falls below the "Empty Litter Line", the litter box will allow you to empty the litter with the press of a single button. Once you press the button, the cylinder will rotate over, dumping out the remaining litter.

1. Please do not allow cats to enter the kitty litter box during the litter emptying process or interrupt the process in any way.
2. Before emptying the litter using the "Empty Litter Button", please make sure the waste collection bin has enough available space.
3. Please do not turn off the device or remove the power cord during the litter emptying process.

REPLACE THE LITTER BOX COVER

1. Rotate the locker counterclockwise which is located on the back of cat litter box.
2. Place the cover back on the litter box. (*The PETKIT logo should face the front opening of the litter box once the cover is placed properly.)

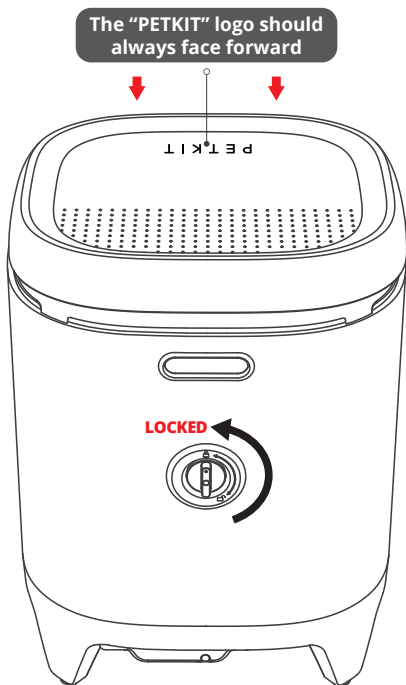

INSTALL THE TRASH BAG

* Make sure you install the trash bag correctly and flatten out the edges of the bag. Otherwise, it may influence the ability of the device to sense the amount of urine in the litter box.

1. Take out the entire waste collection bin.

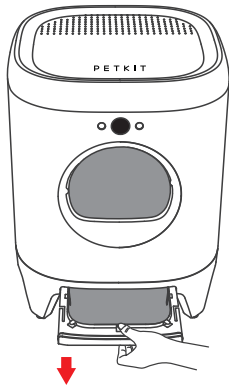

2. Detach the ring used to secure the trash bag onto the waste collection bin.

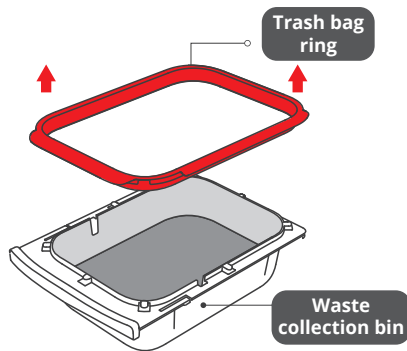

3. Open trash bag all the way up, and hang it from the four trash bag hooks located on the waste collection bin.

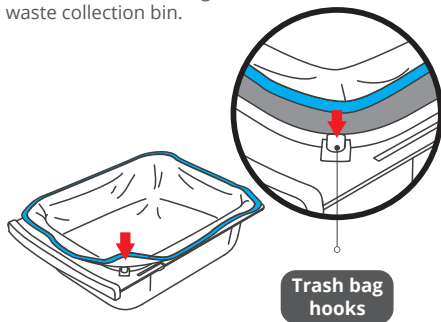

4. Place on the trash bag ring to secure the trash bag in place and put the waste collection bin back into the bottom of the litter box.

*When placing the trash bag ring, make sure the front of the trash bag ring is facing forward.

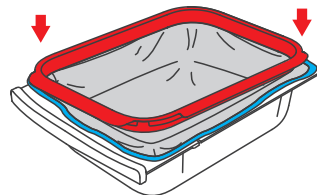

INSERT THE LITTER PAD

Spread out the litter pad and place the two front legs of the litter box in the left and right leg holes of the litter pad. If this step is not done as instructed, it may render the liquid detection function of the odor-removal device ineffective and influence the overall lifespan of the odor-removal device.

* The orange area on the litter pad is the effective range of the thermal sensor. Once the cat enters this area, it will be recognized by the sensor, and the device will automatically cease operation.

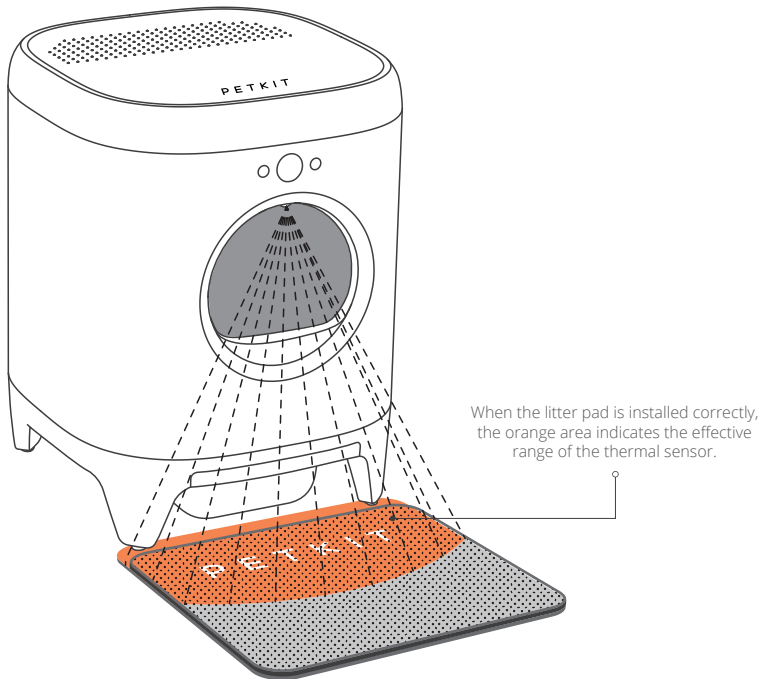

PLUG IN THE POWER CORD, START USING

Take the cord adapter and attach it to the lower slot on the back of the litter box, which is near the bottom. Then plug into a power socket.

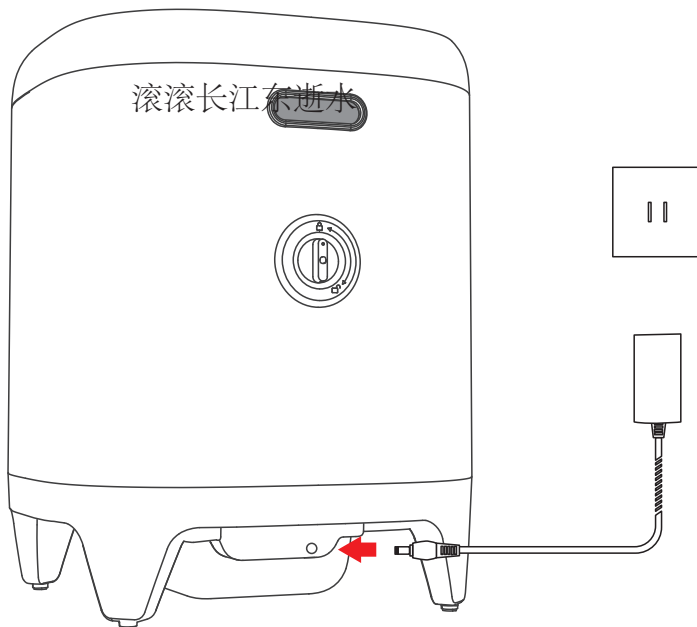

USE THE APP

1. Scan to download the PETKIT APP. After registering in the APP, follow the prompts to your account to your PETKIT Smart Automatic cat Litter Box.



Scan to download
the "PETKIT" APP

2. Use the App to get real-time information and notifications about cat's weight, as well as time and frequency of using the litter box.
*Automatic cleaning and periodic cleaning can only be accessed through the APP.

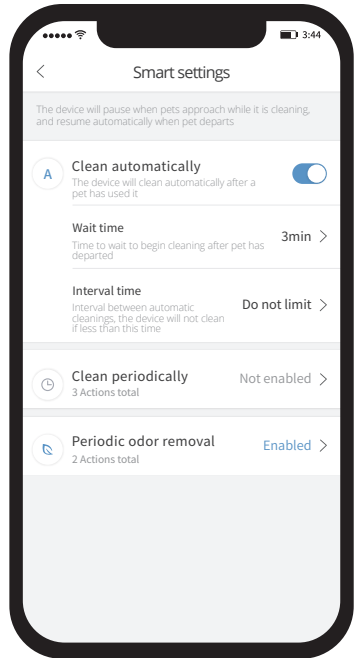

MENU

How to use the menu: Short press the menu button to navigate the menu. The screen will display different functions to choose from. Short press OK to choose a function.



Menu Button

Short Press: Navigate menu
Long Press: Turn on, turn off.



OLED Screen



OK Button

Short Press: Choose menu item.



Begin cleaning litter box



Spray odor-removing solution



Dump all kitty litter into
waste collection bin



Evenly distribute cat litter



Cylinder will rotate back
to original position



Litter box is connected to Wi-Fi,
can be used to update network

DISPLAY GUIDE

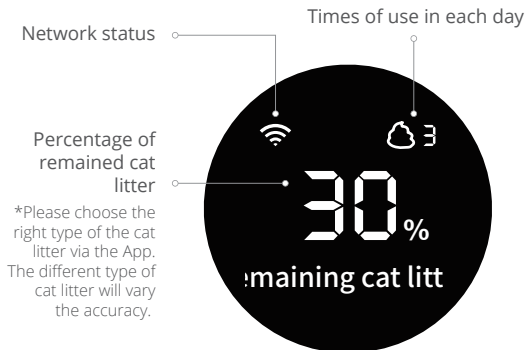

Please check if the cover is properly placed.



Please place the cylinder properly and rotate the locker into the 'LOCKED' position.



If the cat approaches or enters the litter box while it is operation, the litter box will automatically cease operating and send a notification



Please check the App for more malfunction information.

| SCAN THE QR CODE AND WATCH THE CLEAN UP VIDEO



Scan QR Code to Watch a Video on How to Clean Your Litter Box.

PRODUCT CLEANING

Remove cylinder periodically for cleaning.

*It is recommended to wait until the level of kitty litter has gone below the “Empty Litter Line” before removing the cylinder for cleaning.

1. The "Empty Litter Button":

In order to empty out the litter as quick as possible, do not allow the cat to enter the litter box while the emptying process is underway. (*Note: The cylinder can tip easily when full of litter. Please wait until the litter level has gone down before removing. Take careful note of the litter level shown on the “Empty Litter Line” located by the trash symbol on the inside of cylinder. Also check the space remaining in the waste collection bin.)

2. Steps to remove cylinder:

- ① Take off the upper cover.
- ② Rotate the 'locker' into UNLOCKED position.
- ③ Lift the cylinder upwards and take out.

3. To remove sifting net:

- ① Grasp the filter net (as shown in picture 1), and use your fingers to press inward on the curve of the filter net (as shown in picture 2);
- ② After bending the filter net, lift the hooks to remove.

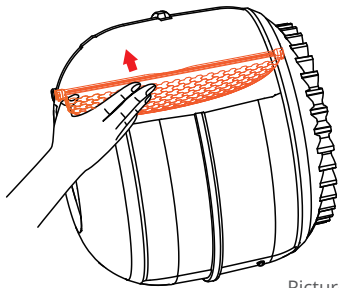

Picture 1

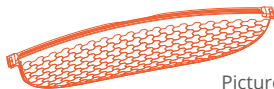

Picture 2

4. Installing the filter net:

- ① Make sure Point A of the sifting net is securely in place, then use your fingers to press inward on the curve of the sifting net;
- ② Once the filter net is sufficiently bent, secure Point B in place.

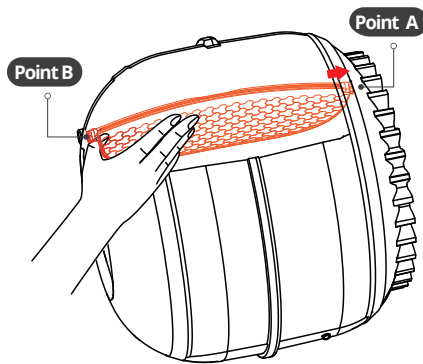

FAQ

Q: Why do rollers rotate when I didn't perform any operation?

A: The machine automatically detects the position between the rollers and returns them to the original positions.

Q: Why does it show prompt that the lid is not placed when I put the lid on the main unit?

A: Check whether the upper lid for the main unit is correctly placed. (PETKIT logo should be on the display side)

Q: Why do the rollers stop when working?

A: When sensors system detects nearby moving subjects, it will shut down the operation for safety.

Q: Will the waste collecting bin full even if the screen doesn't display so?

A: The sensors on the top of the bin will detect whether it is full. To prevent blocking the sensors, squeeze the garbage bag down to the ring.

Q: Why is the display screen off?

A: The display screen will enter the screen protection mode with a dynamic PETKIT logo when the product is not operating for a period of time. The screen will also be turned off when the App shuts it down. You can also modify the brightness level.

Q: How to use App's smart setting?

A: That smart settings for cat toilets include automatic cleaning, set cleaning, and regular deodorization; when there are few cats in the family (within 3), we recommend using the automatic cleaning function. We recommend using the set cleaning function to avoid cleaning too frequently; the device will automatically deodorize during the cleaning process, and regular deodorization can be applied according to the circumstances.

SPECIFICATIONS

Product name	PETKIT PURA X Self-cleaning cat litter box
Product code	P9901
Product dimensions	504mm X 523mm X 642mm
Total weight	≈ 15kg (including power adapter)
Recommended for use with	Cats
Voltage	12V 
Power	24W

Disposal

The European directive 2012 / 19 / CE on Waste Electrical and Electronic Equipment(WEEE), requires that old household electrical appliances must not be disposed in the normal unsorted municipal waste stream. Old appliances must be collected separately in order to optimize the recovery and recycling of the materials they contain and reduce the impact on human health and the environment. The crossed out "wheeled bin" symbol on the product reminds you of your obligation,that when you dispose of the appliance it must be separately collected. Consumers should contact their local authority or retailer for information concerning the correct disposal of their old appliance.

This device complies with part 15 of the FCC Rules. Operation is subject to the following two conditions: (1) This device may not cause harmful interference, and ; (2) this device must accept any interference received, including interference that may cause undesired operation.

FCC warning:

Any Changes or modifications not expressly approved by the party responsible for compliance could void the user's authority to operate the equipment.

Note: This equipment has been tested and found to comply with the limits for a Class B digital device, pursuant to part 15 of the FCC Rules. These limits are designed to provide reasonable protection against harmful interference in a residential installation. This equipment generates uses and can radiate radio frequency energy and, if not installed and used in accordance with the instructions, may cause harmful interference to radio communications. However, there is no guarantee that interference will not occur in a particular installation. If this equipment does cause harmful interference to radio or television reception, which can be determined by turning the equipment off and on, the user is encouraged to try to correct the interference by one or more of the following measures: -Reorient or relocate the receiving antenna.

-Increase the separation between the equipment and receiver.

-Connect the equipment into an outlet on a circuit different from that to which the receiver is connected.

-Consult the dealer or an experienced radio/TV technician for help.

The device has been evaluated to meet general RF exposure requirement.

This equipment complies with FCC radiation exposure limits set forth for an uncontrolled environment. This equipment should be installed and operated with minimum distance 20cm between the radiator & your body.

IC warning

- English:

This device complies with Industry Canada licence-exempt RSS standard(s). Operation is subject to the following two conditions: (1) This device may not cause interference, and (2) This device must accept any interference, including interference that may cause undesired operation of the device.

- French:

Le présent appareil est conforme aux CNR d'Industrie Canada applicables aux appareils radio exempts de licence. L'exploitation est autorisée aux deux conditions suivantes:

(1) l'appareil ne doit pas produire de brouillage, et

(2) l'utilisateur de l'appareil doit accepter tout brouillage radioélectrique subi, même si le brouillage est susceptible d'empêcher le fonctionnement.

The device has been approved for use in EU countries and is therefore provided with the **CE mark**. All necessary documentation is available on the website: www.electric-collars.com
Changes to technical parameters, properties and printing errors reserved.

Service center and distribution

Reedog, sro

Sedmidomky 459/8 101

00 Prague 10

Phone: +1 646 980 4569

Email: info@electric-collars.eu