

PETKIT

VACUBE

User Manual • Užívateľský manuál •
Užívateľský manuál • Használati utasítás

Please read the User Manual carefully before using the product and keep it properly.

Product Description

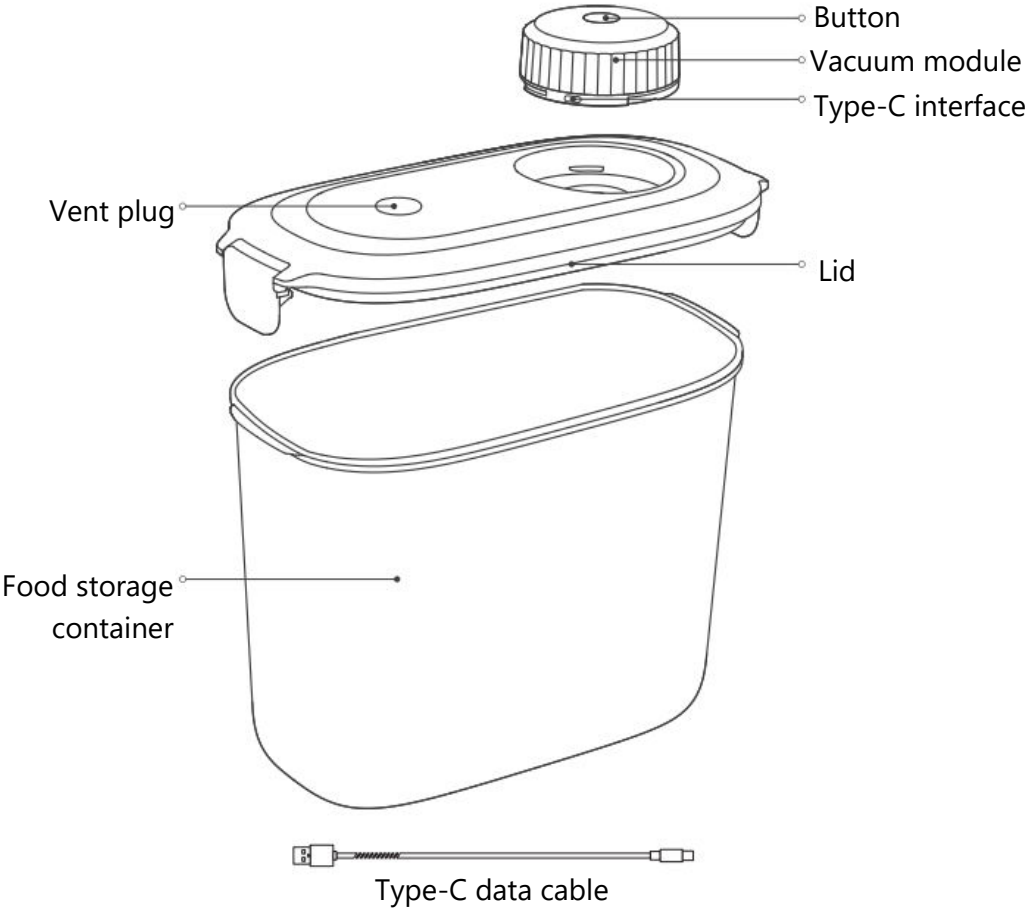

Note: In order to provide a better user experience, we will be implanting periodic product enhancements. Product images shown for illustration purpose only. Actual product may vary from the image shown on the box. For any discrepancies, please refer to the actual product.

How to Use

Before first use, please clean the main body of the food storage container and dry it.



Scan to watch an instructional video on how to use the product.

Activate the vacuum module (only required for first use)

1. Rotate the vacuum module counterclockwise and remove it.

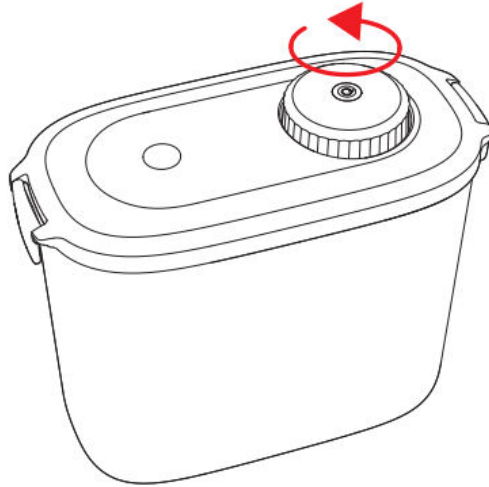

2. Turn on the power switch at the bottom of the vacuum module.

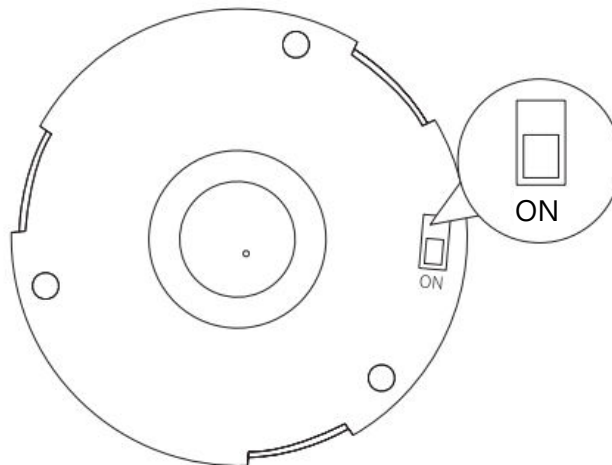

3. Rotate the vacuum module clockwise and install it back to the lid.

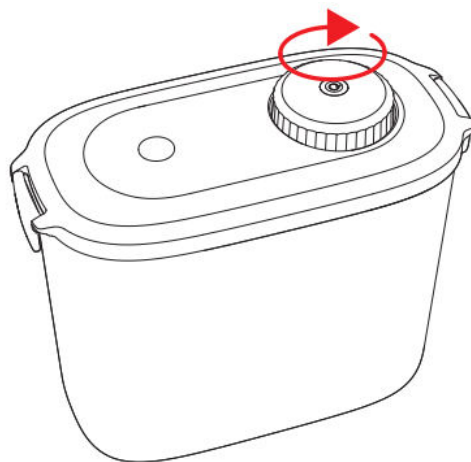

Pour in pet food

1. Open the buckles on both sides and remove the lid.

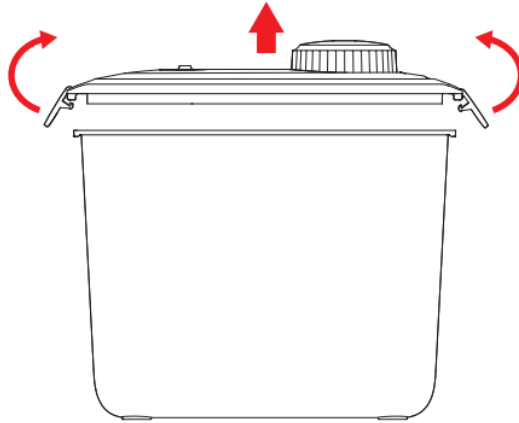

2. Pour in pet food.

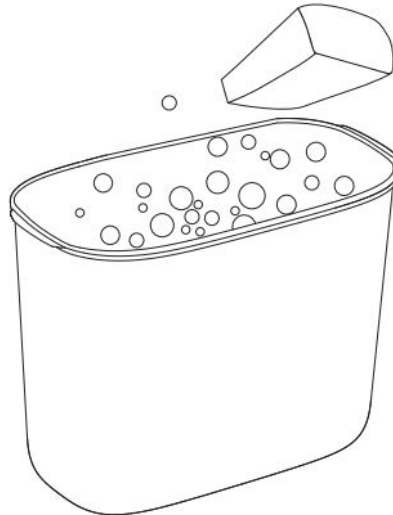

Vacuumize

1. Cover the lid and fasten the buckles on both sides.

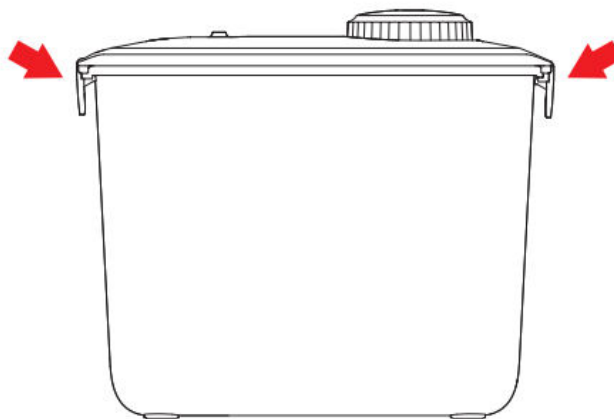

2. Double click the button on the top of the vacuum module to begin vacuumizing (when vacuumization is completed, the blue light flashes 3 times, accompanied by 3 buzzes).

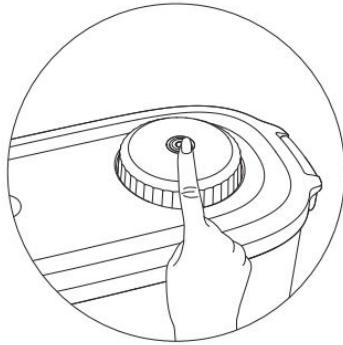

How to vent under vacuum

1. Gently pull up one side of the vent plug and hear the sound of "ci~", which means that the vent is in progress.

Do not move the vent plug with force to prevent it from falling off and affecting normal use. If it has fallen off, just install it back by yourself.

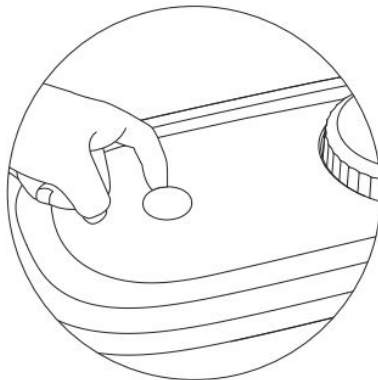

2. When there is no venting sound, open the buckles on both sides and remove the lid of the food storage container.

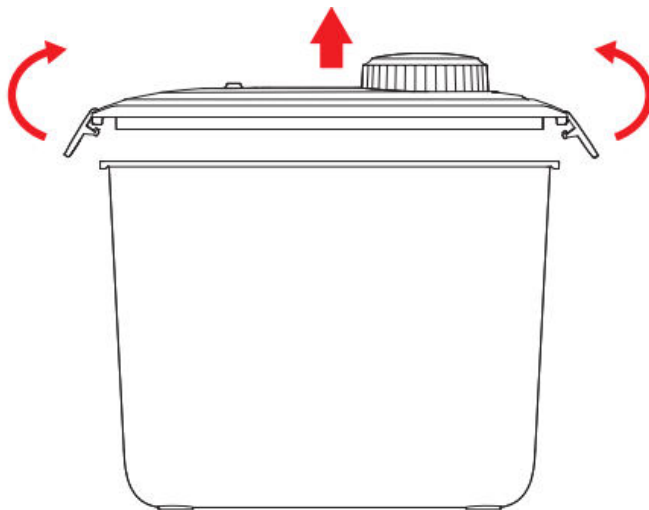

How to charge the vacuum module

1. Rotate the vacuum module, counterclockwise and remove it.
2. Connect the Type-C data cable.
3. When connected to the power supply, blue light flashes slowly.
4. Charge completed, blue light on.
5. Rotate the vacuum module clockwise and install it back to the lid.

Note: when the vacuum module is removed for charging, the vacuum state in the food storage container will not be affected.

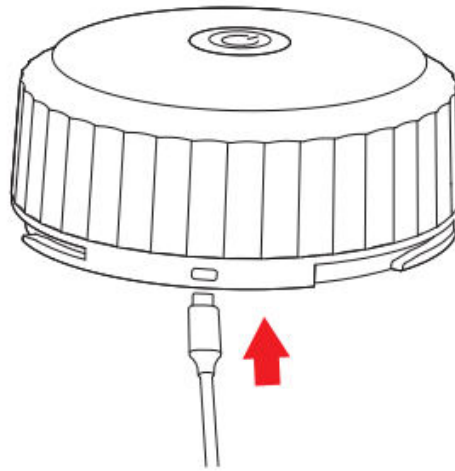

Cleaning and Maintenance

1. Rotate the vacuum module counterclockwise and remove it.
2. Wash all components with detergent and clean water (except vacuum module)
3. Be sure to dry all cleaned components.
4. Reinstall the components in turn.
5. Return to normal use.

Basic Specifications

Product Name	Petkit Vacube
Product Code	P580
Product Dimensions	350mm x 180mm x 300mm
Max Capacity	About 10.4L
Product Weight	2.1kg
Input	5V = 1A
Rated Power	5W

Indicator Light and Buzzer Sound

- Turn on the power switch for the first time: The orange and blue lights flash alternately with buzzes.
- Manual vacuumize completed: Blue light flashes 3 times quickly, accompanied by 3 buzzes.
- Low battery: Orange light flashes slowly.
- Charging: Blue light flashes.
- Charge completed: Blue light on.
- Device failure: Orange light on, accompanied by a 3-second-long buzzes.

A Message to Our Valued Customers

- Thank you for choosing to purchase the PETKIT VACUBE. We at PETKIT have done our best to make life easier for you and your pet through the miracle of technology.
- Before using this product, please carefully read the user's manual. By setting up and using product, you acknowledge that you have already read and accept the safety measures listed below.
- We are not liable and will not accept responsibility for any accidents or injuries that result from improper use of this product.
- Concerning this notice, we reserve the right of interpretation and revision.

User Safety Guide

Failure to follow the safety guide outlines below may result in device malfunction or other unexpected accidents.

- Please install and use product exactly as instructed in the User's Manual.
- Please make sure the device is placed on a level surface. Do not overturn the device, otherwise it may not function properly.
- The vacuum module contains electrical components, so to avoid shoring out or otherwise damaging the vacuum module when cleaning, do not pour water directly on the vacuum module. To clean, simply wipe the vacuum module with a cloth.
- When using the product, please keep away from water source and heat source to avoid damage and potential safety hazards.
- Do not plug and unplug the power supply when your hands are wet, otherwise there may be electric leakage.
- Do not pull the Type-C data cable too hard, otherwise it may cause electric leakage, short circuit or fire.
- If any abnormality is found in the Type-C data cable, stop using the data cable immediately and replace it in time, otherwise there may be electric leakage, short circuit or fire.

The device has been approved for use in EU countries and is therefore provided with the **CE mark**. All necessary documentation is available on the website: www.electric-collars.com
Changes to technical parameters, properties and printing errors reserved.

Service center and distribution

Reedog, sro

Sedmidomky 459/8 101

00 Prague 10

Phone: +1 646 980 4569

Email: info@electric-collars.eu