

P E T K I T

Fresh Element Solo

User Manual

Product Summary

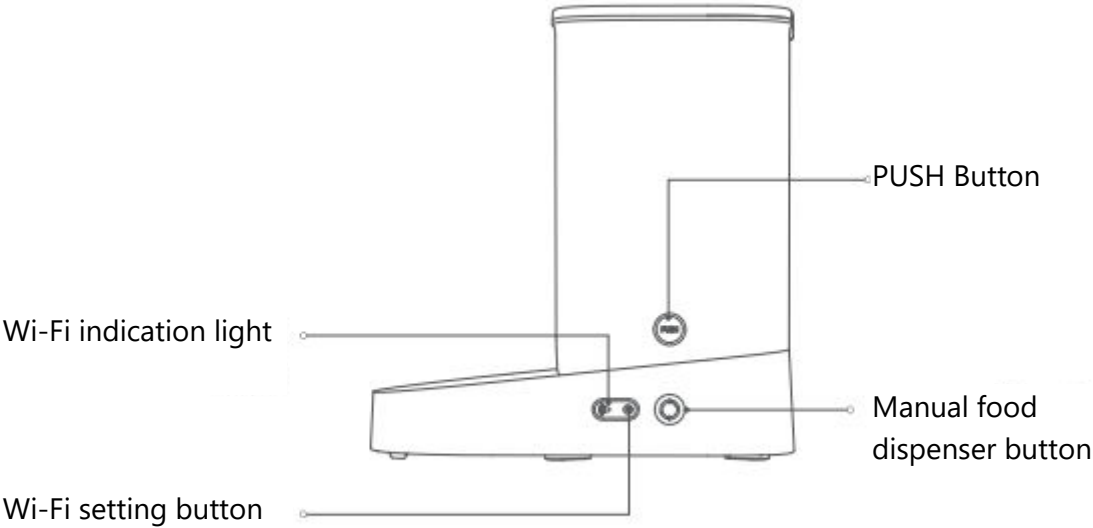
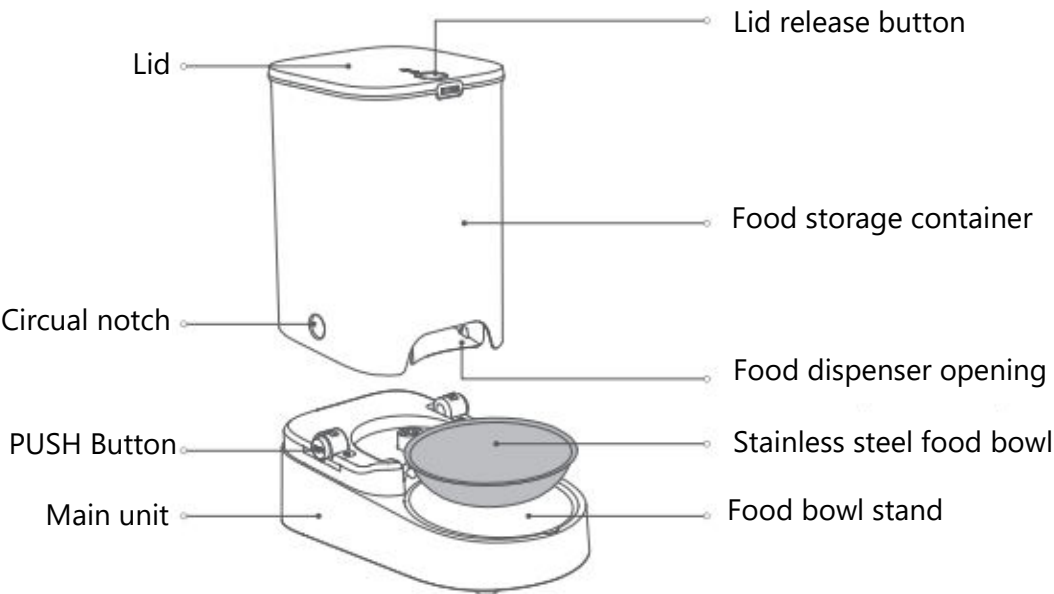

Note: In order to provide a better product, we will make periodic product enhancements. If the illustrations do not match what you see on the device, please refer to the device as standard.

Bottom

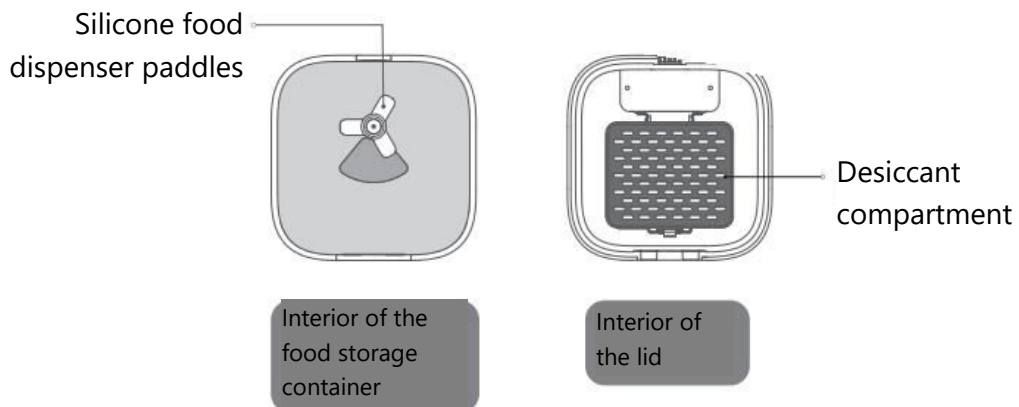
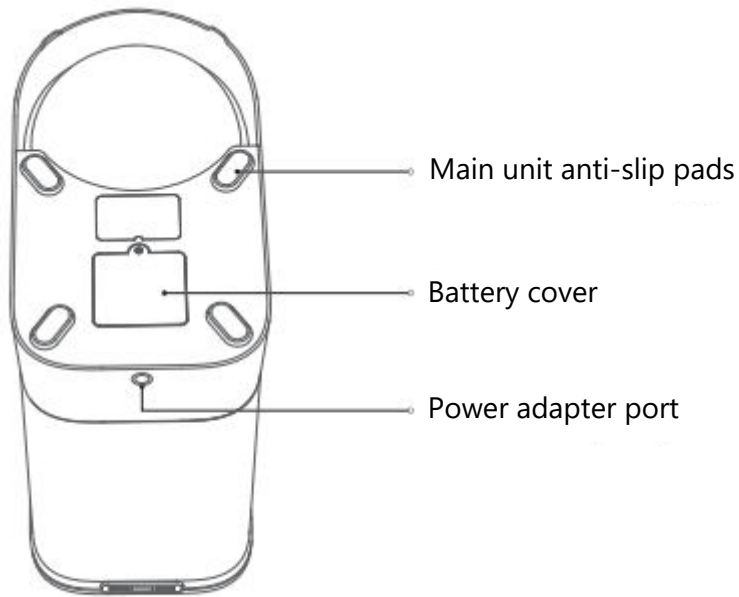

Quick Start Guide (Device Setup)

When installing your device, make sure there is no food already in the food storage container.

Connect the power adapter

Take out the power adapter cord and attach it to the power adapter port on the bottom of the main unit.

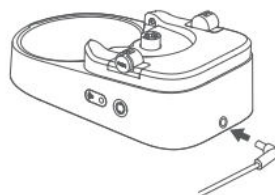

Install the main unit

1. Place the main unit on a level surface.
2. Press and hold the PUSH button and place the circular notches on both sides of the food storage container downward toward the PUSH buttons until the PUSH button is fully stuck into the circular notches. (As shown in the figure below).
3. Take the stainless-steel food bowl and place it in the food bowl stand.



Install the backup batteries. (If you want to install batteries, you will need to buy the batteries separately).

(Before installing batteries, make sure there is no food in the storage container.)

1. Take out the screw and remove the battery cover.
2. Take 5AAA batteries and place them in the battery compartment. (Pay attention to the orientation of the positive and negative ends.)
3. Put the battery cover back on and tighten down the screw.

We strongly recommend checking and replacing the batteries before leaving the device unattended for an extended period of time. Always replace batteries that have a low charge. (Only use alkaline batteries)



Quick Start Guide (Opening the Lid and Adding Food)

Open the lid

Use your thumb to press down on the lid release button and slide the lid in the OPEN direction as indicated in the illustration bellow, lift the lid at the same time.

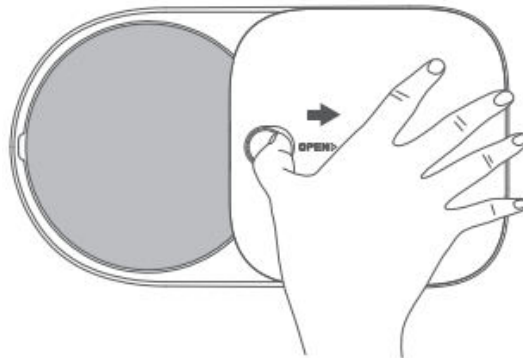

Insert desiccant

Open the desiccant compartment, take the desiccant packet, and lay it down evenly in the compartment. Then close the desiccant compartment.

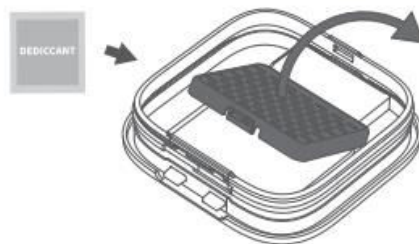

Add pet food

1. Add pet food (do not exceed the MAX line)
2. Close the lid: Notch the back of the lid into the two holes located at the top of the food storage container, then press the front of the lid down.

It is suggested that the size of dry pet food should be no bigger than 12mm.



Self-Check Chart:
Size of Pet Food Pellets

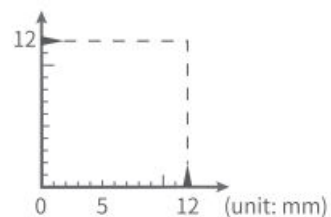

Dry pet food or freeze-dried pellet size should be below 12mm.

Using the App

Connect the App

Download the PETKIT App and complete your registration via the App. Go to the App's main page and follow the instructions to add the Petkit Smart Feeder SOLO and connect your device.



Scan the QR code to download the PETKIT App

Use the App to remotely control food dispensing

Using the App, you can set a feeding schedule. The pet feeder will automatically dispense food each day based on your setting. When your pet has eaten, you will receive a notification. This can help you better control when your pet eats and how much they eat each time.

Manual feeding

Hold down on the manual food dispenser button to dispense food. Release the button to stop dispensing food.

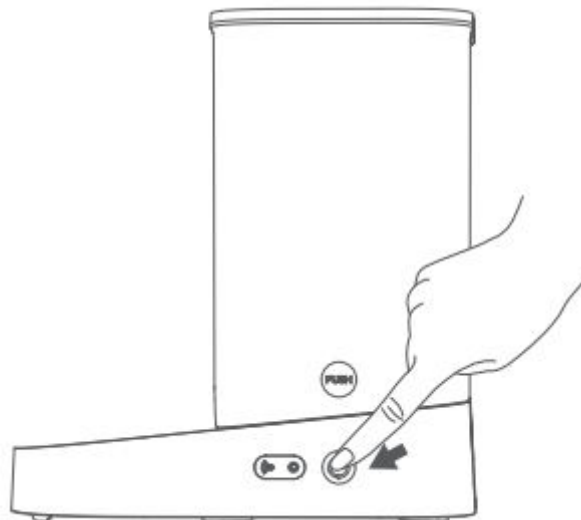

Indication Light

Wi-Fi Indicator Light	Status
Blinking slowly	Device is offline, there is no internet connection
Blinking quickly	Device is connecting to the Wi-Fi
On (constant)	Device is connected to the internet
Off	Indicates the wi-fi indication light has been turned off

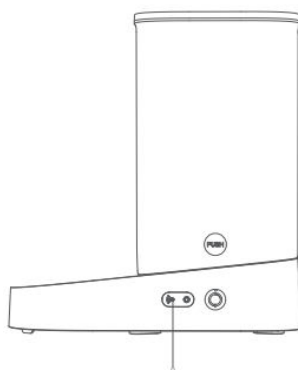

Wi-Fi indication light

Cleaning the Device

1. Open the lid and remove the desiccant packet.
2. Take off the food storage container and place the feeder on a level surface. Press down on the PUSH button on one side, and at the same time lean the container toward the other side and slide it off.
3. Remove the stainless-steel food bowl.
4. Clean each component one at a time, starting with the food storage container (including the food dispenser paddles inside), the lid, and the stainless-steel food bowl. We recommend using an appropriate amount of soap when cleaning, then rinsing and drying the components after you are done.

Remember that the main unit cannot get wet.

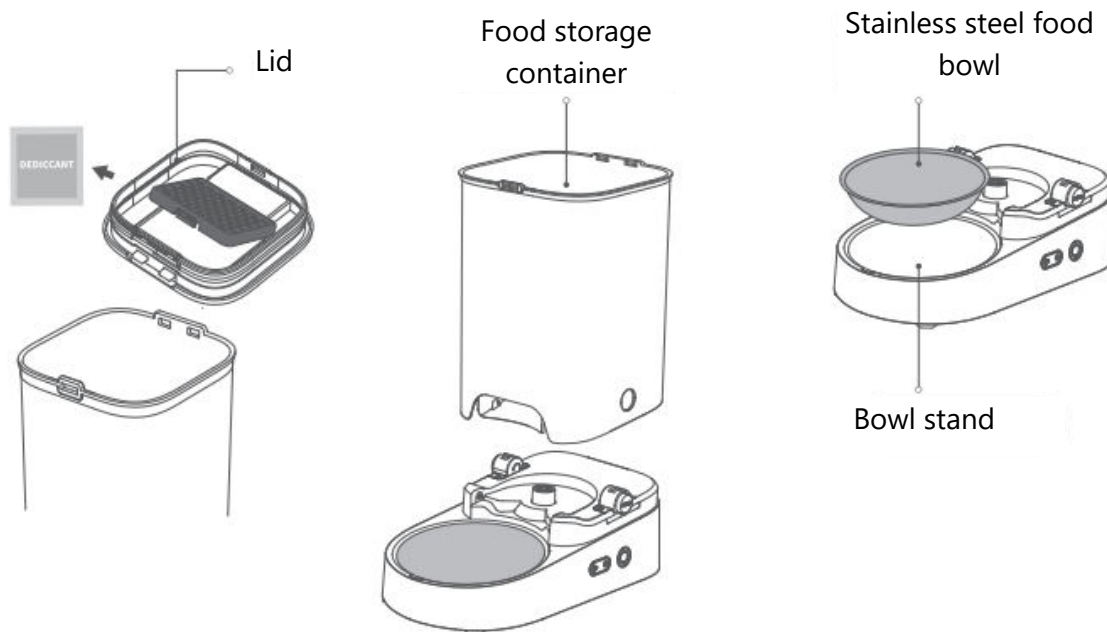

5. After cleaning and drying, reinstall each component in the correct order, starting with the food storage container, then the lid, then the stainless-steel food bowl. (Make sure each component is completely dry before reinstalling)

When installing the food storage container, if you are unable to get it to lock into place, try rotating the food dispenser paddles until the PUSH button snaps into place in the circular notches in the food storage container. (See illustration 1 below)

Illustration 1

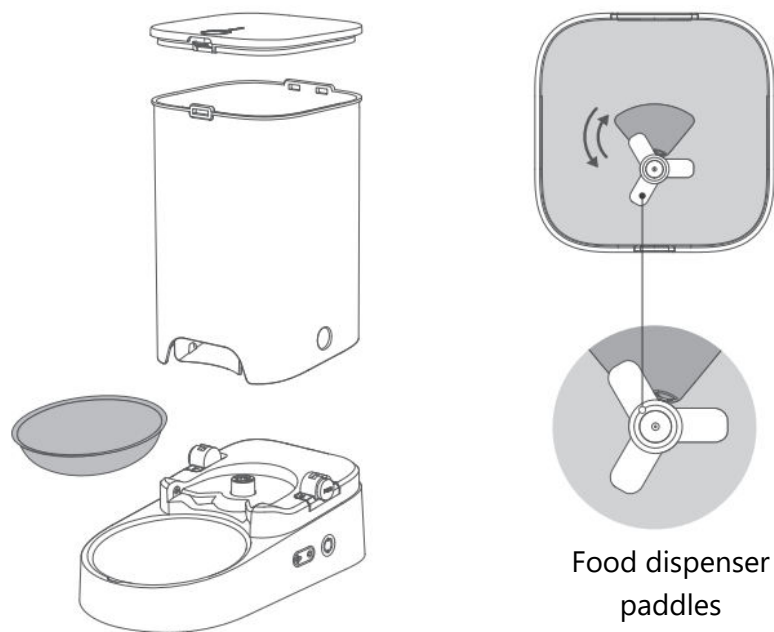

FAQ

The Feeder SOLO is offline:

That the feeder loses connection to your home's router will cause the device get offline.

Possible causes for this problem include:

1. The power supply of the feeder was disconnected. If it happens, your router will not work, and your Feeder will switch to battery power. If there are no batteries installed, then your device will cease working until power is restored. Before the batteries die, the Feeder will operate normally. However, the App will be unable to connect to your device. Records of feeding during this time will be labelled as "unknown". (Note: once the internet connection is restored, you will only be able to update a maximum of 10 feeding records, and during this time you will be unable to adjust the feeding schedule.)
2. The internet in your home was disconnected (this can be caused by a number of reasons, such as your internet provider cutting service). If this happens, the feeder will continue to operate as normal, but the App will not be able to track your feeder's status. Any feeding logs from this period will be marked as "unknown". (Note: After the connection to the internet is restored, you will only be able to update a maximum of 10 feeding logs, and at during this time you will be unable to adjust the feeling schedule).

The Feeder SOLO is not dispensing food correctly:

The feeder uses fixed volume to determine the servings of food it dispenses. Each serving is approximately 10g. The actual weight of each serving is affected by the size and density of the food pellets. When the food storage container is full, each serving is relatively consistent in weight. In most cases, you can adjust the amount dispensed in your settings. When the food level is low, the portion size may shrink. Please make sure there is always enough food in the food storage container.

Basic Specifications

Product name	Petkit Fresh Element SOLO Smart Pet Feeder
Product code	P570
Product dimensions (mm)	167mm x 296mm x 316mm
Recommended for	For cats and small breed dogs
Total weight of product	1.32kg
Wireless Connection	Wi-Fi
Rated voltage	6V 
Rated power	6W/1000mA

The device has been approved for use in EU countries and is therefore provided with the **CE mark**. All necessary documentation is available on the website: www.electric-collars.com
Changes to technical parameters, properties and printing errors reserved.

Service center and distribution

Reedog, sro

Sedmidomky 459/8 101

00 Prague 10

Phone: +1 646 980 4569

Email: info@electric-collars.eu