

## Thule Chariot Jog Kit

# ➤ Instructions

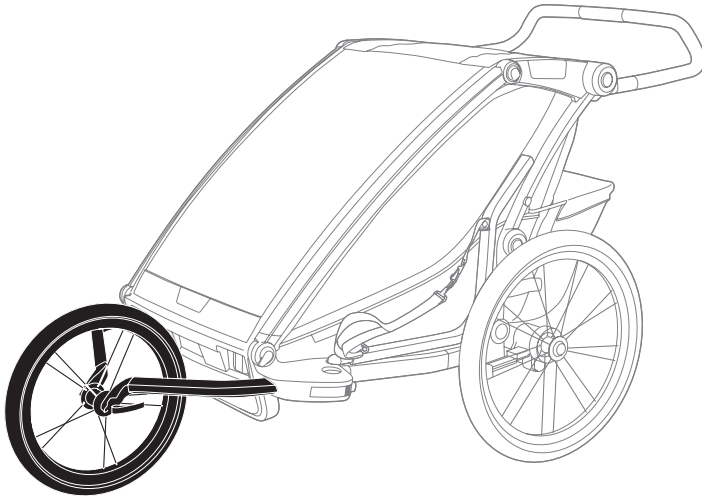

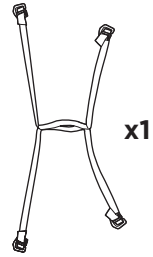
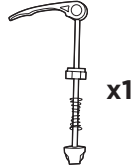
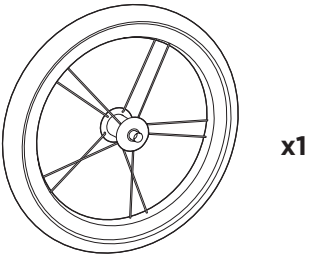
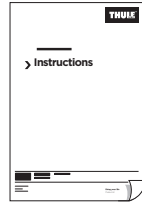
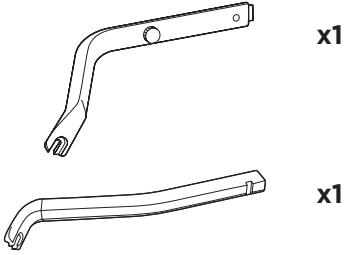

1

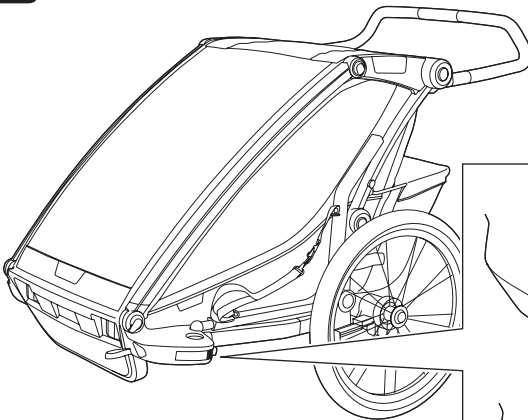

A

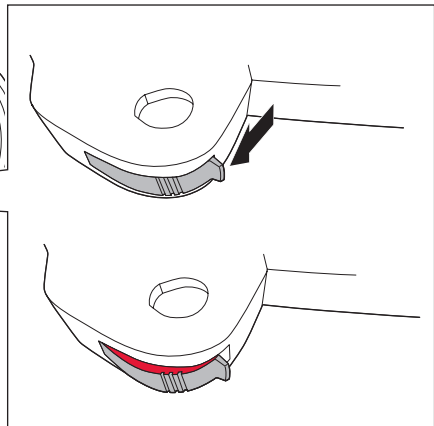

**B**

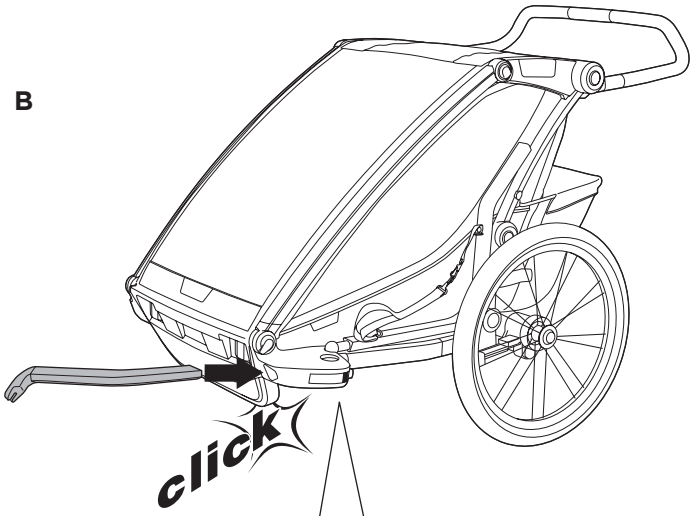

**C**

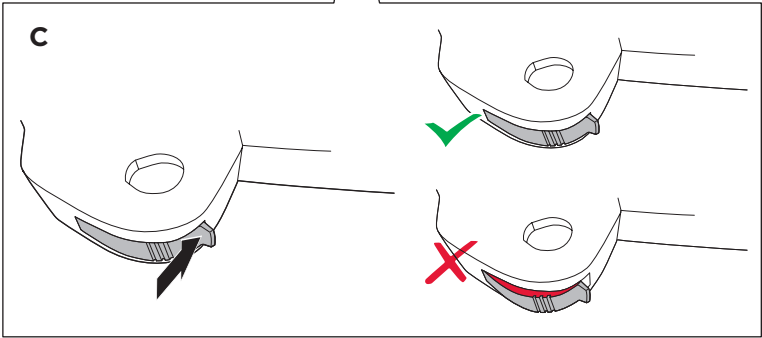

**D**

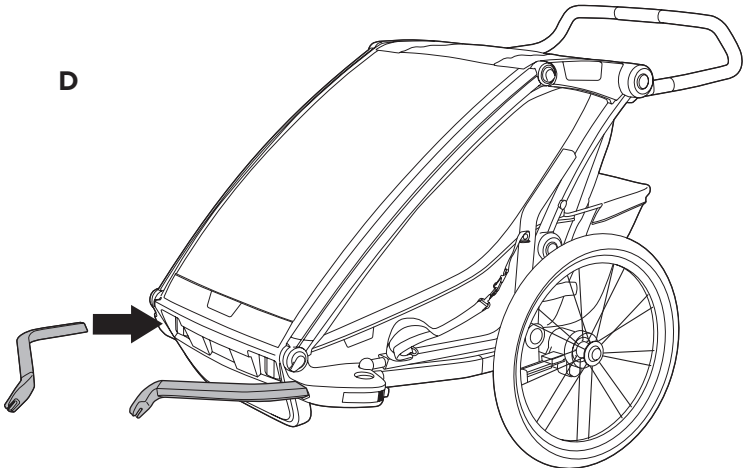

2

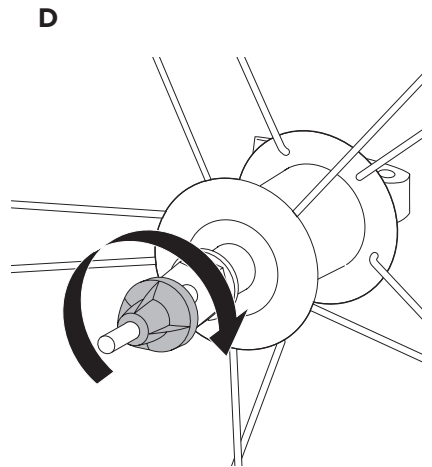
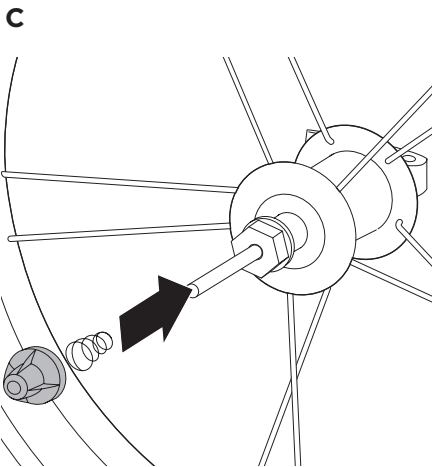
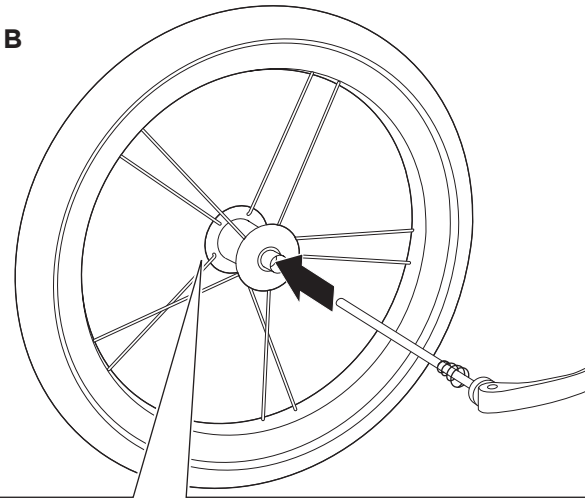
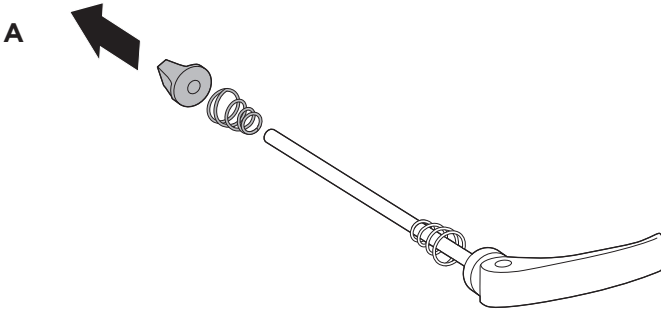

3

A

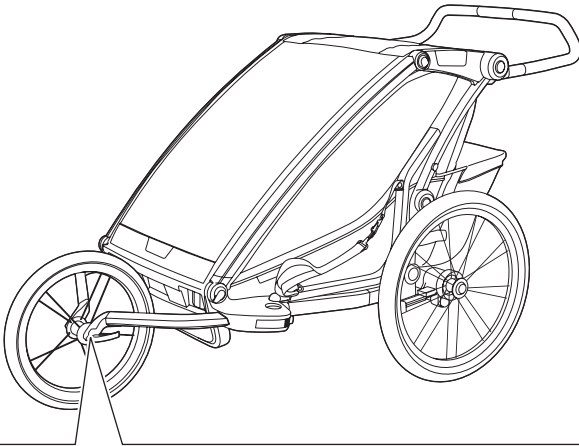
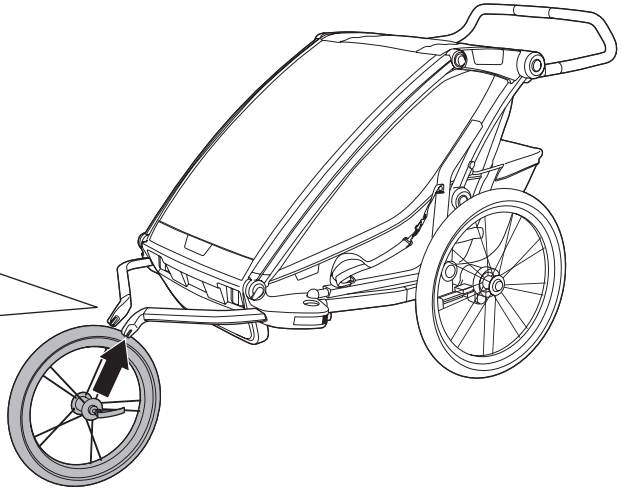
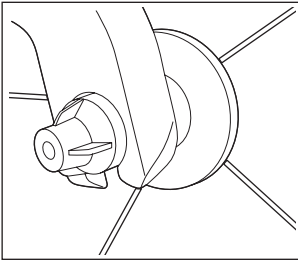

B

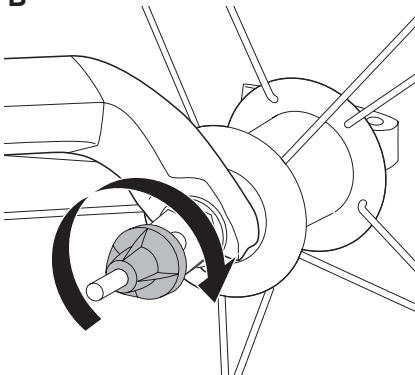

C

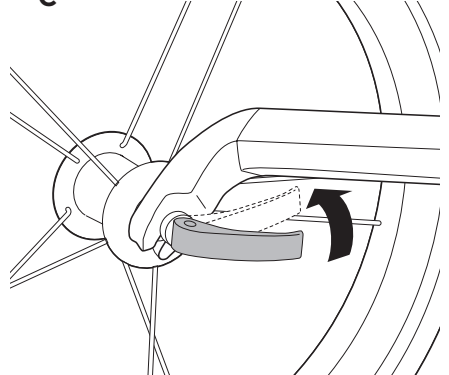

# 4

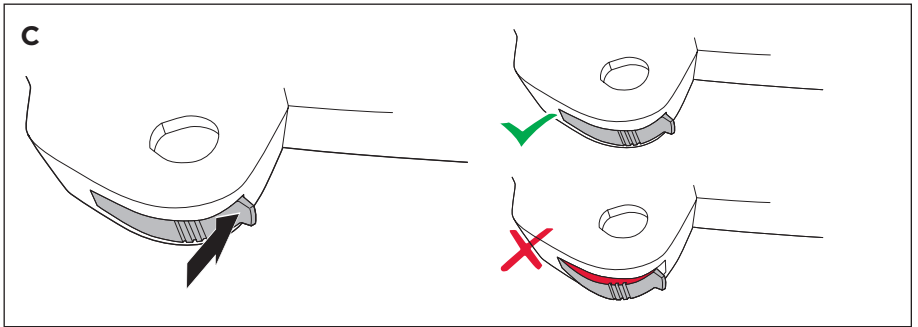
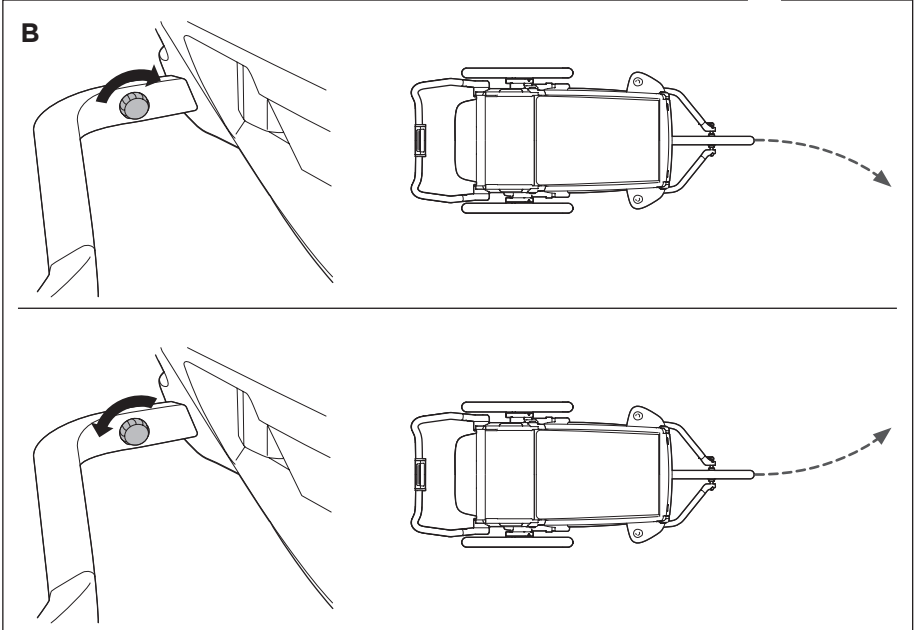
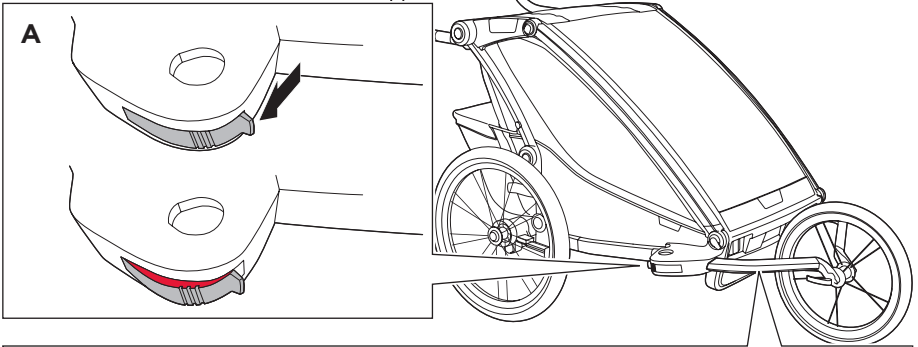

**i**

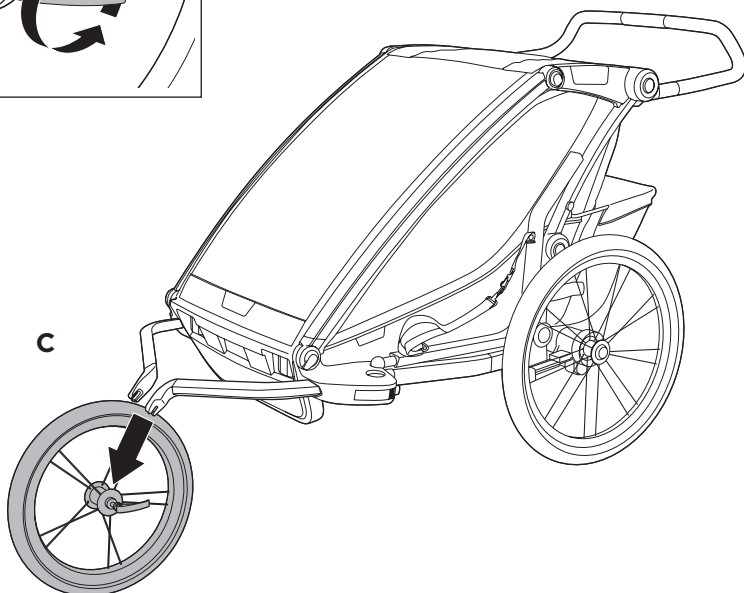
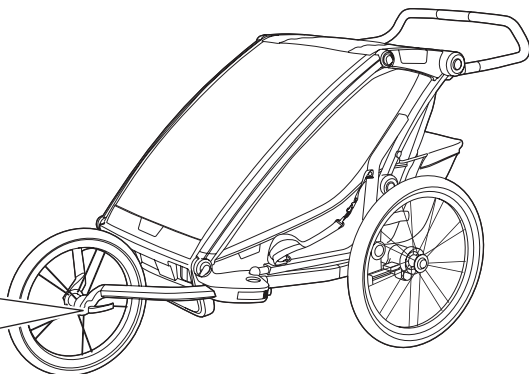
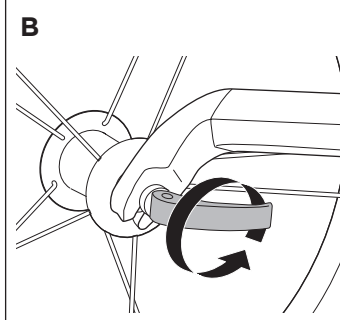
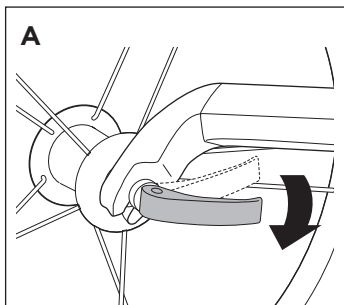
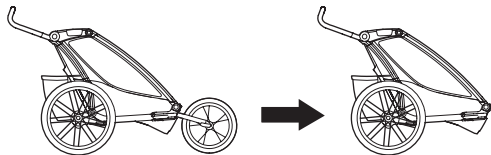

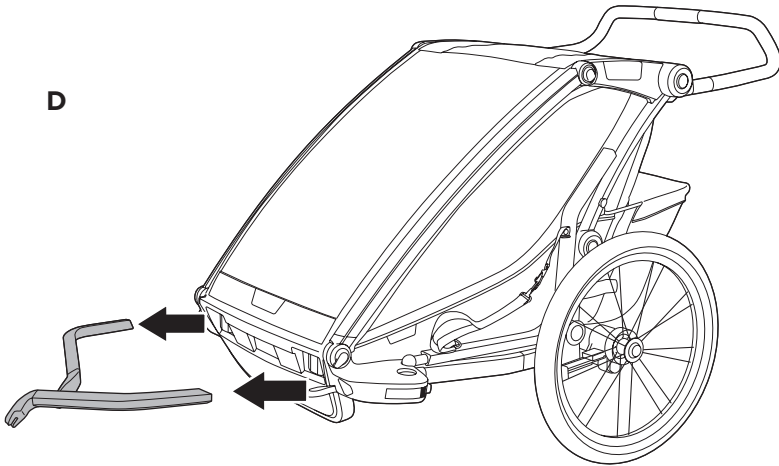
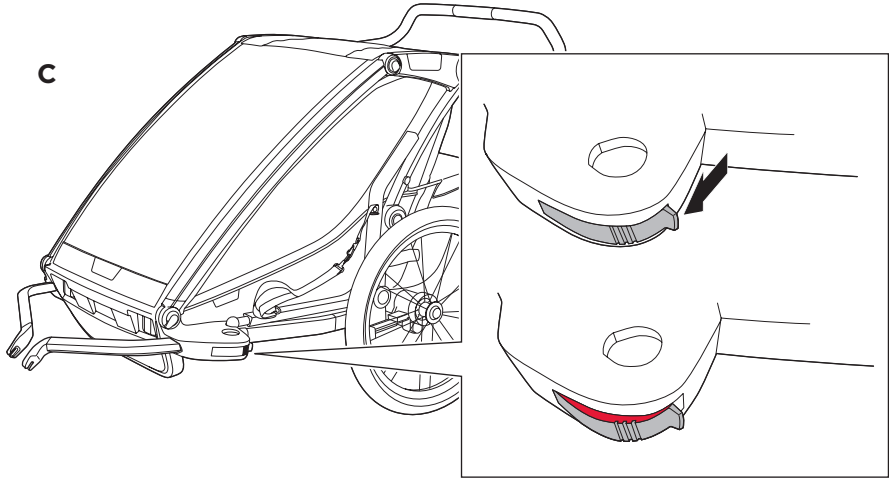



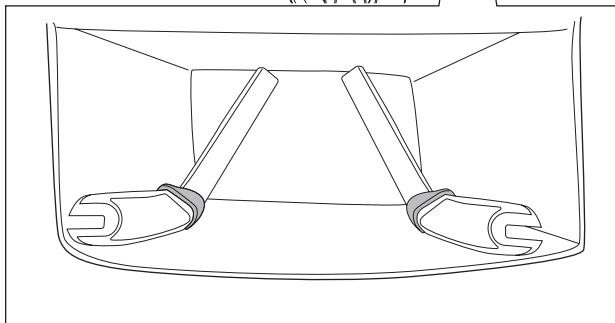
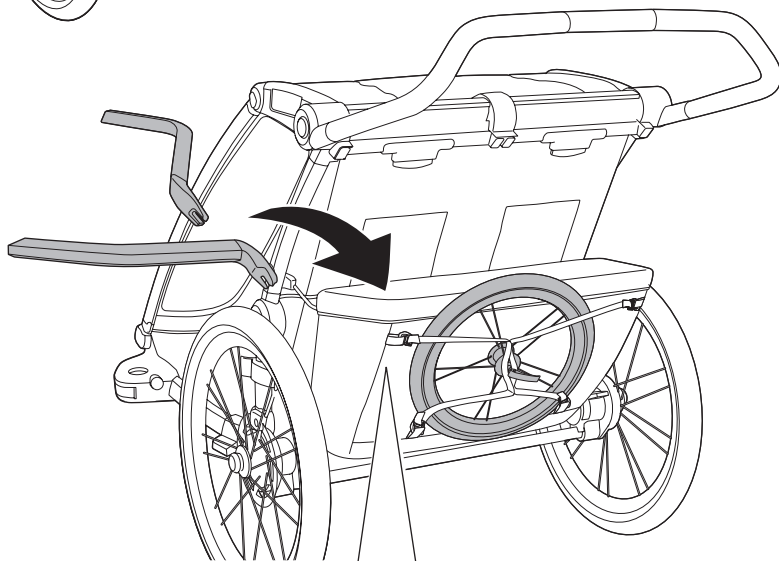
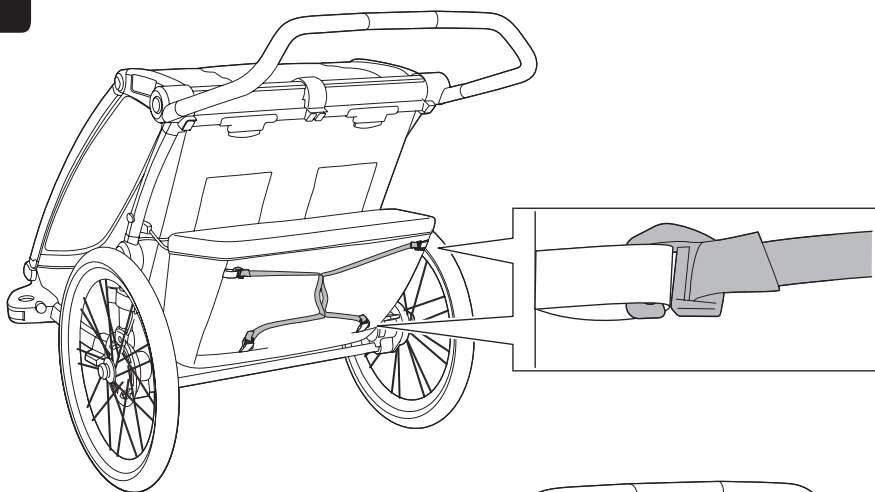

EN

## ⚠ **WARNING:**

**FALL HAZARD.** Wheel can detach and cause tip over. Pull on the wheel to assure it is securely attached.

DE

## ⚠ **ACHTUNG:**

**STURZGEFAHR.** Das Rad kann sich lösen und einen Überschlag verursachen. Ziehen Sie am Rad, um seine sichere Befestigung zu überprüfen.

FR

## ⚠ **AVERTISSE- MENT :**

**RISQUE DE CHUTE.** La roue peut se détacher et renverser la remorque. Tirez sur la roue pour vérifier qu'elle est correctement attachée

NL

## ⚠ **WAARSCHU- WING:**

**RISICO VAN VALLEN.** Het wiel kan losraken waardoor alles kantelt. Trek aan het wiel om er zeker van te zijn dat het stevig vastzit.

IT

## ⚠ **AVVERTENZA:**

**PERICOLO DI CADUTA.** La ruota potrebbe sganciarsi e causare un ribaltamento. Fissare la ruota saldamente

ES

## ⚠ **ADVERTENCIA:**

**RIESGO DE CAÍDAS.** La rueda puede desprenderse y provocar una caída. Tire de la rueda para asegurarse de que esté sujeta de manera segura

PT

## ⚠ **AVISO:**

**PERIGO DE QUEDA.** A roda pode soltar-se e provocar o tombo do veículo. Puxe a roda para garantir que esta se encontra presa de forma segura

SV

## ⚠ **VARNING:**

**VÄLTRISK.** Hjulet kan lossna och få vagnen att välta. Dra i hjulet och kontrollera att det sitter fast ordentligt.

DK

## ⚠ **ADVARSEL!**

**FARE FOR FALD.** Hjulet kan gå løs og forårsage væltning. Træk i hjulet for at kontrollere, at der er sikkert monteret

(NO)

## ⚠ ADVARSEL:

**FARE FOR FALL.** Hjulet kan løsne og føre til at du velter. Stram til hjulet for å sikre at det sitter godt fast.

(FI)

## ⚠ VAROITUS:

**PUTOAMISVAARA.** Pyörä voi irrota ja aiheuttaa kaatumisen. Varmista pyörän kiinnitys vetämällä sitä.

(PL)

## ⚠ OSTRZEŻENIE:

**NIEBEZPIECZEŃSTWO UPADKU.** Koło może odcepić się, doprowadzając do przewrócenia. Należy pociągnąć za koło, aby upewnić się, że jest bezpiecznie zamocowane.

(CS)

## ⚠ VAROVÁNÍ:

**NEBEZPEČÍ PÁDU.** Kolo se může odpojit a způsobit převrácení. Zkuste předním kolem trhnout směrem od vozíku, abyste měli jistotu, že je bezpečně připojeno.

(HU)

## ⚠ FIGYELMEZTE-

### TÉS:

**ELESÉS VESZÉLYE:** A kerék leválhat, ami miatt a kerékpár feldőlhet. Annak ellenőrzéséhez, hogy biztonságosan van-e rögzítve, húzza meg a kereket.

(RU)

## ⚠ ПРЕДУ-

### ПРЕЖДЕНИЯ:

**ОПАСНОСТЬ ПАДЕНИЯ.**

Колесо может отсоединиться, что приведет к опрокидыванию коляски. Потяните за колесо, чтобы проверить, надежно ли оно закреплено.

(ZH)

## ⚠ 警告：

小心摔倒。车轮可能脱落，导致翻车危险。请务必检查车轮状况，确保牢固。

(JA)

## ⚠ 警告:

落下の危険があります。ホイールが外れると転倒するおそれがあります。ホイールを引っ張って、しっかり固定されていることを確認してください。



Thule Sweden AB, Box 69, 330 33 Hillerstorp, SWEDEN  
Thule Canada Inc., 2308 Portland Street SE, Calgary, AB, T2G 4M6



info@thule.com  
Phone: 800-238-2388



www.thule.com